

492229

Foot Operated Hydraulic Lift Table

- Top and base 12 gauge steel.
- 2 rigid and 2 swivel 5" diameter rubber casters.
- Floor lock.
- Optional phenolic resin, polyurethane and steel caster wheels.
- Precision telescoping guide tubes.

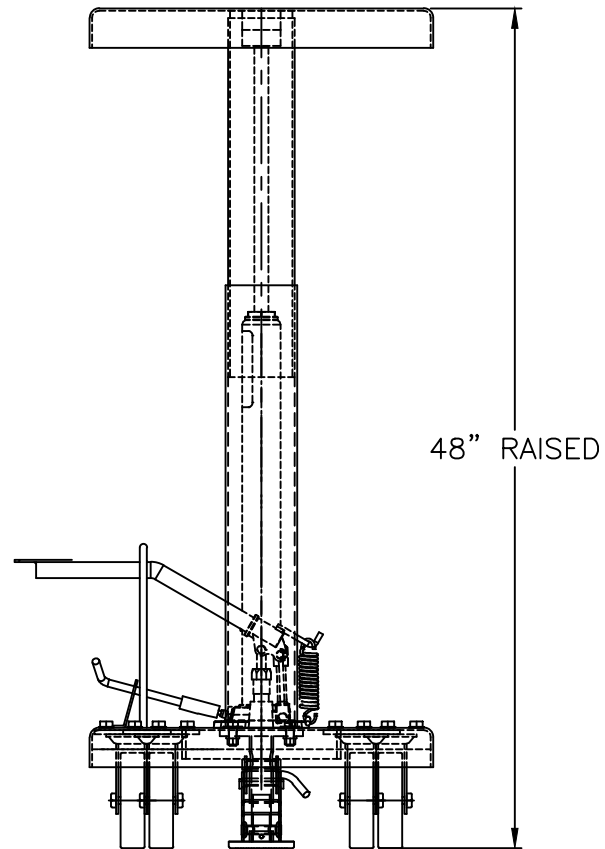
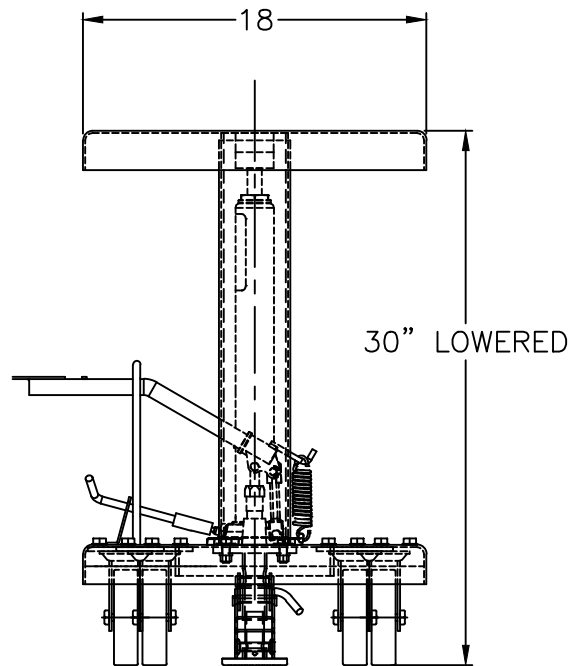
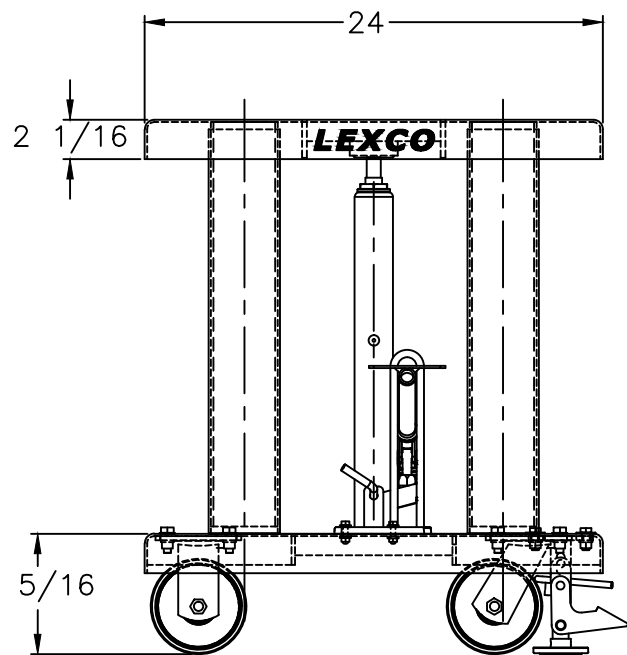
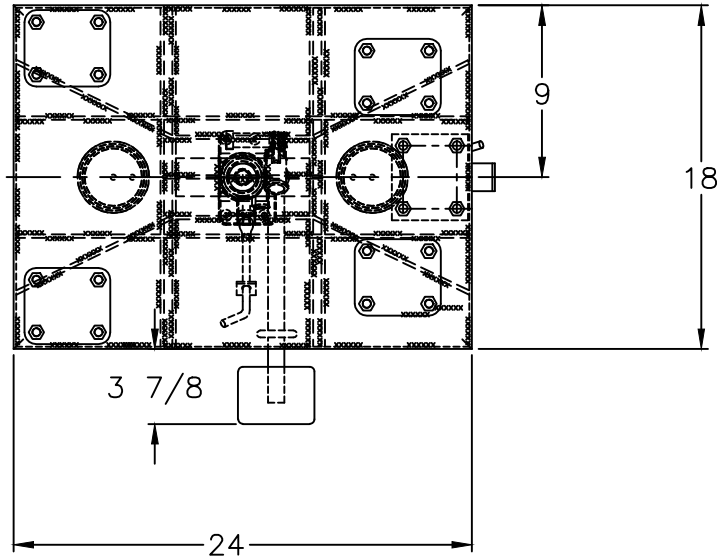

Specs

- Capacity: 400 lbs.
- Table size: 18" x 24"
- Lowered height: 30"
- Raised height: 48"
- Caster size: 5"
- Lift: 18"
- Weight: 119 lbs
- Base: Flat

THIS DRAWING IN ALL PARTICULARS IS WESCO INDUSTRIAL PRODUCTS INC. PROPERTY. ALL RIGHTS OF DESIGN, INVENTION OR USE OF ARE RESERVED.

REV.	ECN & DATE	APP	<b>WESCO INDUSTRIAL PRODUCTS INC.</b>		REV	
			LANSDALE PENNA. 19446			
			PART NAME HT-400-FR			DRAWN:
			TOLERANCE UNLESS OTHERWISE SPECIFIED			CHECKED:
			SCALE:			APP. ENGR.
FRACTION 3 PLACE DECIMAL 2 PLACE DECIMAL		SCALE:				
± 1/64 ± .005 ± .01		B- 492229				
ANGULAR ± 1-1/2'		SHEET 1 OF 1				
BREAK ALL SHARP EDGES AND REMOVE ALL BURRS						