

BILL OF MATERIAL

ITEM	PART NO.	DESCRIPTION	QTY.
1	273112	FRONT WHEEL	2
12	273116	WIRE ROPE	1
18	273114	INTERVAL	2
19	273113	CROWN BLOCK	1
20	273118	LOCKING NUT	2
21	273119	DOUBLE EDGE BLOT	1
22	273120	WASHER	2
23	273117	GUARD	1
26	273121	RATCHET STRUCTURE	1
32	273111	REAR WHEEL	2
	273070	HARDWARE	1
8	273123	AXLE-CABLE PULLEY	1
10	273124	RETAINING RING	2

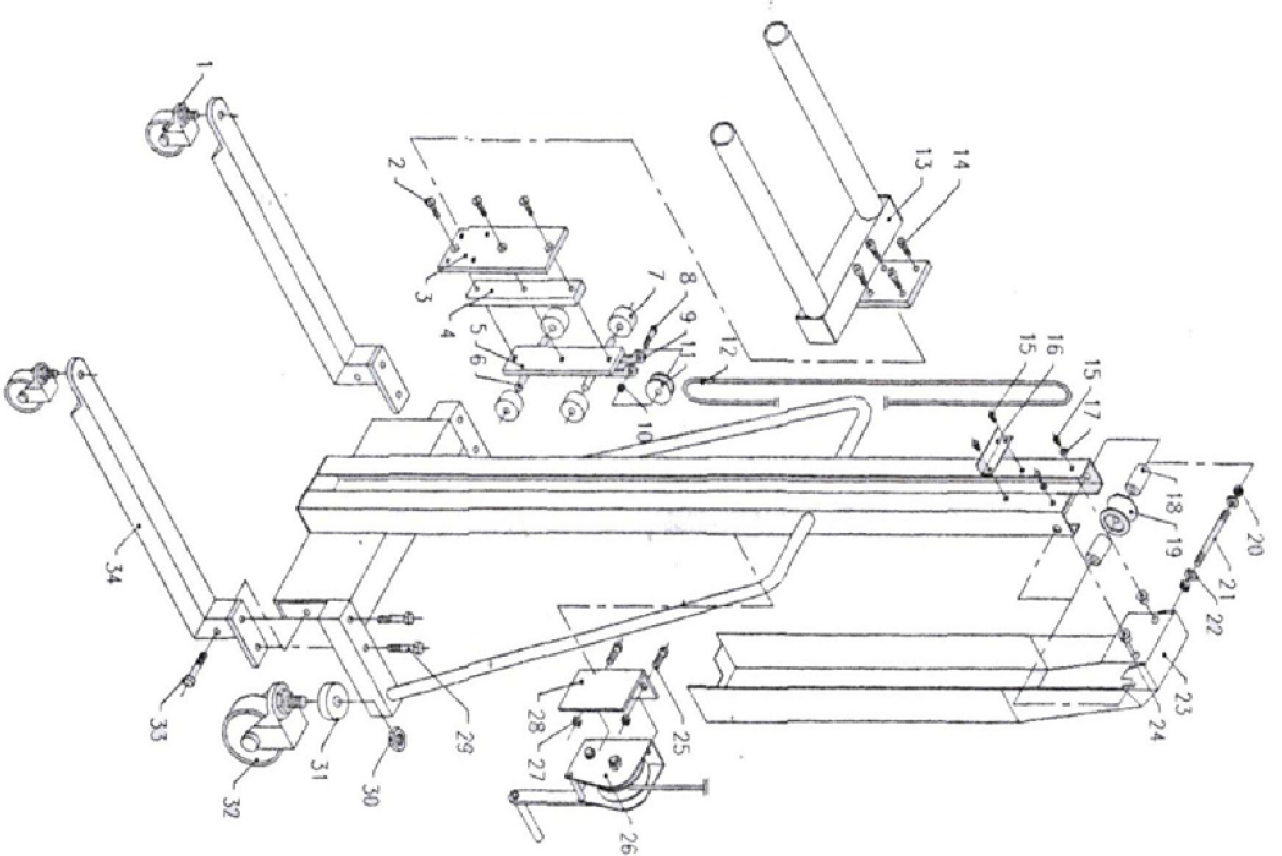

MODEL: MOL
 LOWERED HEIGHT: 5 IN.
 RAISED HEIGHT: 58.5 IN.
 WEIGHT: 104 LBS.
 PLATFORM SIZE: 18 IN. x 23 IN.
 CAPACITY: 220 LBS.
 LOCKING SWIVEL
 CASTER: 5 IN. x 1.25 IN.
 LOAD WHEELS: HARD RUBBER
 2.75 IN. x 1.25 IN.
 LOAD CENTER: HARD RUBBER
 9.25 IN.

THIS DRAWING IS ALL PARTICULARS IS WESCO INDUSTRIAL PRODUCTS INC. PROPERTY. ALL RIGHTS OF DESIGN, INVENTION OR USE OF ARE RESERVED.

PRINT ISSUED
 MAY 13, 2008
 WESCO MANUFACTURING
 ENGINEERING DEPARTMENT

WESCO INDUSTRIAL PRODUCTS INC.
 PENNA. 19446
 LANSDALE

MANUAL OFFICE LIFT

PART NAME: MANUAL OFFICE LIFT
 DRAWN: RDS 05-13-08
 CHECKED: APP. ENR.
 SCALE: 1" = 1"

REVISIONS: 1
 FUNCTION: 3 PLACE ORIGINAL
 MODIFY: 1-1-12
 SHEET: 1 OF 1
 BREAK ALL SHARP EDGES AND REMOVE ALL BURRS

C-272467