

POWERED STACKERS

Features:

- Adjustable base legs available on fork models.
- Fixed platforms 24x24, 24x27, 30x32
- Reinforced frame and base.
- Double chain, lift support.
- Heavy-duty pump.
- Ergonomic "D" handles.
- 110V AC models available.

FIXED PLATFORM MODELS

Model: PSPL-90-3032-30S-2K
 Lift Height: 90"
 O.A.H: 104"
 Weight: 517
 Capacity: 2,000 lbs
 Load Center: 18"
 Platform LxW: 30" x 32"
 Base Leg ID/OD: 30"/36"

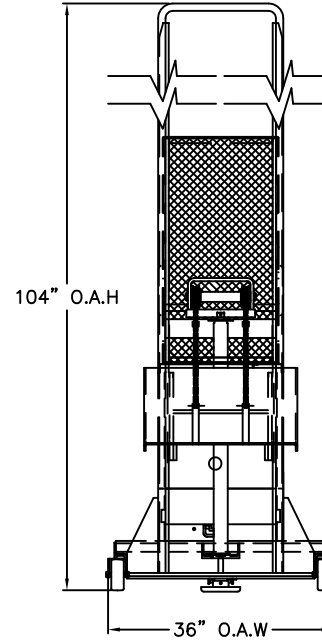
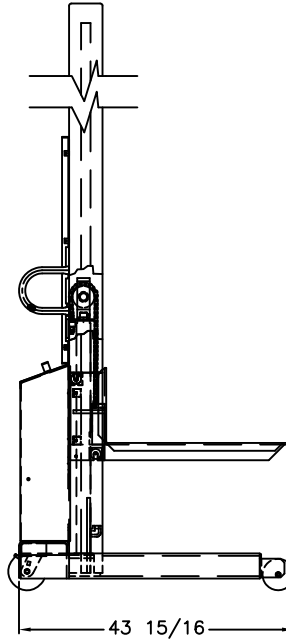

**2,000 LBS POWER STACKER PARTS LIST
86"/90" LIFT**

1	051181	HYDRAULIC CYLINDER	1
2	109101	POWER UNIT	1
3	109099	BATTERY	1
4	109104	VOLTMETER	1
5	052779	BATTERY CABLE (NEG.)	1
6	052780	BATTERY CABLE (POS.)	1
7	109150	BATTERY CHARGER	1
8	125824	HYDRAULIC HOSE	1
9	052726	REMOTE CONTROL ASS'Y	1
10	109325	SWITCH	1
11	050784	LIFT CHAIN ASS'Y	2
12	050776	ROLLER CARRIER ASS'Y	2
13	052010	FLOOR LOCK	1
14	053769	WHEEL	2
15	150024	CASTER	2
16	109117	SOLENOID	1

HYDRAULIC CYLINDER PARTS LIST

17	051105	CYLINDER	1
18	051138	PISTON	1
19	050006	CYLINDER CAP	1
20	220171	SEAL KIT	1

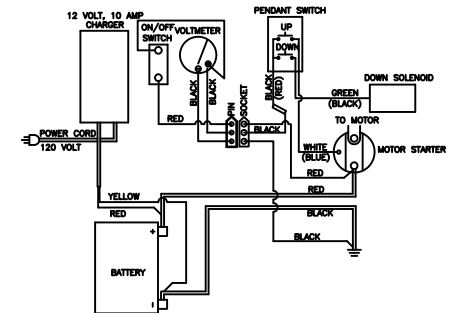

WIRING DIAGRAM

THIS DRAWING IN ALL PARTICULARS IS WESCO INDUSTRIAL PRODUCTS INC. PROPERTY. ALL RIGHTS OF DESIGN, INVENTION OR USE OF ARE RESERVED.

PRINT ISSUED

OTC. 16, 2006

WESCO MANUFACTURING
ENGINEERING DEPARTMENT

REV.	APP	WESCO INDUSTRIAL PRODUCTS INC.	
		NORTH WALES	PENNA. 19454
EDN & DATE	REVISIONS	PART NAME	
		PSPL-90-3032-30S-2K	
		TOLERANCE UNLESS OTHERWISE SPECIFIED	
		FRACTION	3 PLACE DECIMAL 2 PLACE DECIMAL
		± 1/64	± .005 ± .01
		ANGULAR ± 1-1/2'	SHEET 1 OF 2
		BREAK ALL SHARP EDGES AND REMOVE ALL BURRS	
		DRAWN: KL 08-07-01	
		CHECKED: PS 08-16-01	
		APP. ENGR.	
		SCALE: 1" = 20"	
		B-261087	