

261067

POWERED STACKERS

Features:

- Adjustable base legs available on fork models.
- Fixed platforms 24x24, 24x27, 30x32
- Reinforced frame and base.
- Double chain, lift support.
- Heavy-duty pump.
- Ergonomic "D" handles.
- 110V AC models available.

ADJUSTABLE FORK MODELS

Model: PSFL-86-42-50S-1.5K
 Lift Height: 86"
 O.A.H: 104"
 Weight: 635
 Capacity: 1,500 lbs
 Load Center: 24"
 Fork W/L: 3"/42"
 Base Leg ID/OD: 50"/56"

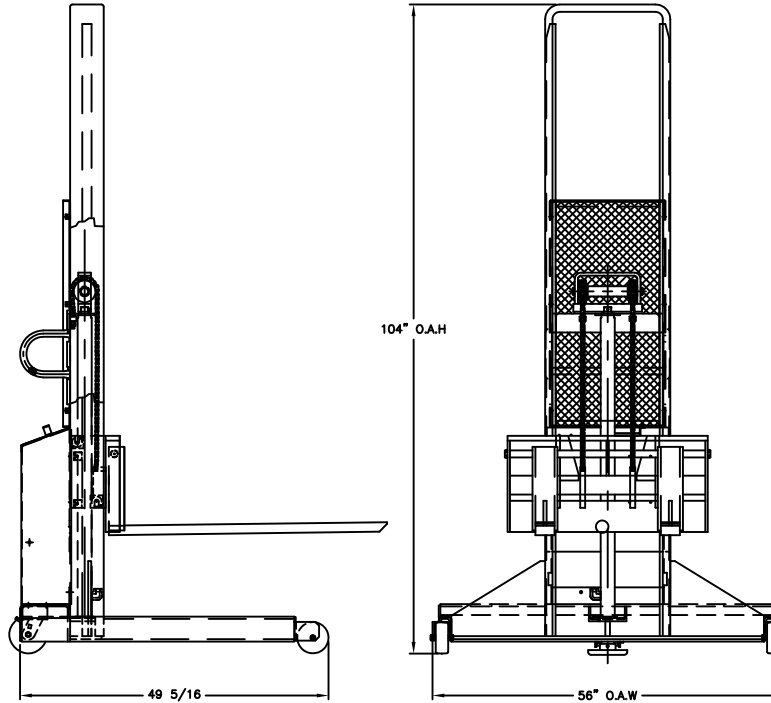

**1,500 LBS POWER STACKER PARTS LIST
86"/90" LIFT**

1	051181	HYDRAULIC CYLINDER	1
2	109101	POWER UNIT	1
3	109102	BATTERY	1
4	109104	VOLTMETER	1
5	052779	BATTERY CABLE (NEG.)	1
6	052780	BATTERY CABLE (POS.)	1
7	109150	BATTERY CHARGER	1
8	125824	HYDRAULIC HOSE	1
9	052726	REMOTE CONTROL ASS'Y	1
10	109325	SWITCH	1
11	050784	LIFT CHAIN ASS'Y	2
12	050776	ROLLER CARRIER ASS'Y	2
13	052010	FLOOR LOCK	1
14	053769	WHEEL	2
15	150024	CASTER	2
16	109117	SOLENOID	1

HYDRAULIC CYLINDER PARTS LIST

17	051105	CYLINDER	1
18	051138	PISTON	1
19	050006	CYLINDER CAP	1
20	220171	SEAL KIT	1

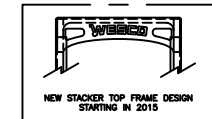

THIS DRAWING IN ALL PARTICULARS IS WESCO INDUSTRIAL PRODUCTS INC. PROPERTY. ALL RIGHTS OF DESIGN, INVENTION OR USE OF ARE RESERVED.

PRINT ISSUED

OTC. 16, 2006

WESCO MANUFACTURING
ENGINEERING DEPARTMENT

REV.	APP	WESCO INDUSTRIAL PRODUCTS INC.		NORTH WALES PENNA. 19454	
	ECN & DATE	REVISIONS	PART NAME		DRAWN: KL 08-07-01
			PSFL-86-42-50S-1.5K		CHECKED: PS 08-16-01
			TOLERANCE UNLESS OTHERWISE SPECIFIED		APP. ENGR.
		FRACTION	3 PLACE DECIMAL	2 PLACE DECIMAL	SCALE: 1" = 20"
		± 1/64	± .005	± .01	
		ANGULAR ± 1-1/2°	SHEET 1 OF 2		B- 261067
		BREAK ALL SHARP EDGES AND REMOVE ALL BURRS			REV