

**POWERED STACKERS**

Features:

- Adjustable base legs available on fork models.
- Fixed platforms 24x24, 24x27, 30x32
- Reinforced frame and base.
- Double chain, lift support.
- Heavy-duty pump.
- Ergonomic "D" handles.
- 110V AC models available.

**FIXED PLATFORM MODELS**

Model: PSPL-80-3032-30S-2K  
 Lift Height: 80"  
 O.A.H: 94"  
 Weight: 539  
 Capacity: 2,000 lbs  
 Load Center: 18"  
 Platform LxW: 30" x 32"  
 Base Leg ID/OD: 30"/36"

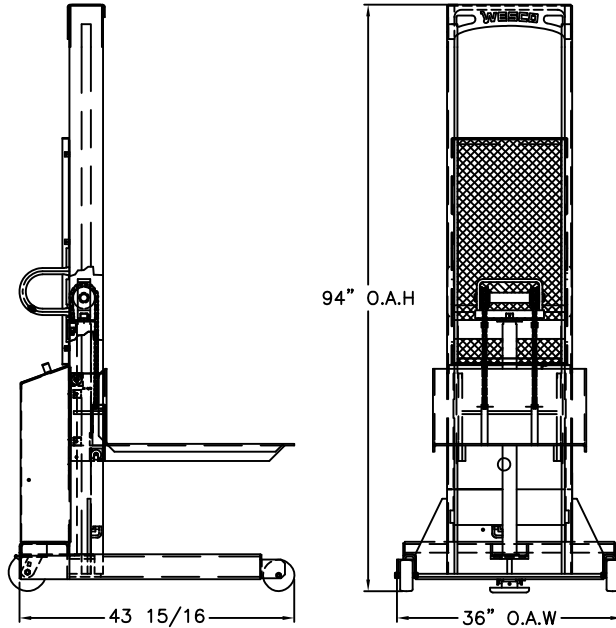

**2,000 LBS POWER STACKER PARTS LIST  
76"/80" LIFT**

1	051158	HYDRAULIC CYLINDER	1
2	109101	POWER UNIT	1
3	109099	BATTERY	1
4	109104	VOLTMETER	1
5	052779	BATTERY CABLE (NEG.)	1
6	052780	BATTERY CABLE (POS.)	1
7	109150	BATTERY CHARGER	1
8	125824	HYDRAULIC HOSE	1
9	052726	REMOTE CONTROL ASS'Y	1
10	109325	SWITCH	1
11	050783	LIFT CHAIN ASS'Y	2
12	050776	ROLLER CARRIER ASS'Y	2
13	052010	FLOOR LOCK	1
14	053769	WHEEL	2
15	150024	CASTER	2
16	109117	SOLENOID	1

**HYDRAULIC CYLINDER PARTS LIST**

17	051072	CYLINDER	1
18	051137	PISTON	1
19	050006	CYLINDER CAP	1
20	220171	SEAL KIT	1

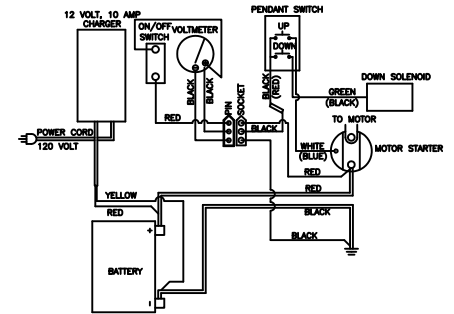

**WIRING DIAGRAM**

THIS DRAWING IN ALL PARTICULARS IS WESCO INDUSTRIAL PRODUCTS INC. PROPERTY. ALL RIGHTS OF DESIGN, INVENTION OR USE OF ARE RESERVED.

**PRINT ISSUED**

OTC. 16, 2006

WESCO MANUFACTURING  
ENGINEERING DEPARTMENT

**WESCO INDUSTRIAL PRODUCTS INC.**  
NORTH WALES PENNA. 19454

PART NAME: **PSPL-80-3032-30S-2K**

DRAWN: KL 08-07-01  
 CHECKED: PS 08-16-01  
 APP. ENGR.

TOLERANCE UNLESS OTHERWISE SPECIFIED

FRACTION	3 PLACE DECIMAL	2 PLACE DECIMAL
± 1/64	± .005	± .01

ANGULAR ± 1-1/2° SHEET 1 OF 2

BREAK ALL SHARP EDGES AND REMOVE ALL BURRS

SCALE: 1" = 20"

**B-261058**