

260051

REPLACEMENT PARTS LIST

64"/68" Stacker

1	260143	CHAIN ROLLER ASS'Y	1
2	050771	LIFT CHAIN ASS'Y (64/68")	1
3	108519	STABILIZER ROLLER	4
	051617	STABILIZER ROLLER KIT	
4	108517	PLATFORM ROLLER	4
5	053769	WHEEL: 5x2, PHENOLIC ASS'Y	2
6	054265	CASTER: SWIVEL 4x2 PHENOLIC	2
7	150001	FLOOR LOCK: NEW STYLE	1
8	051161	JACK ASS'Y (64/68")	1
	052723	SEAL KIT	1
	050750	PUMPING PEDAL ASS'Y (PL/SPL)	1
	050752	RELIEF PEDAL ASS'Y (PL/STCKR)	1
	050774	PUMPING RELEASE VALVE KIT	1
	050468	MAGNET SPACER ASS'Y	1

"S" STANDARD & "E" CONOMY LINE PLATFORM HYDRAULIC STACKERS

- Floor locks, safety screen and foot guard are standard on all models.
- Forks touch the floor on all fork models.
- Front phenolic wheels are 5" diameter.
- Rear Phenolic swivel casters are 4" diameter.
- Hydraulic jack manufactured by WESCO in U.S.A
- Frame and lift heights vary among models.
- "S" tandard line features one piece platform guide rail.
- "E" conomy line offers an economical price value.

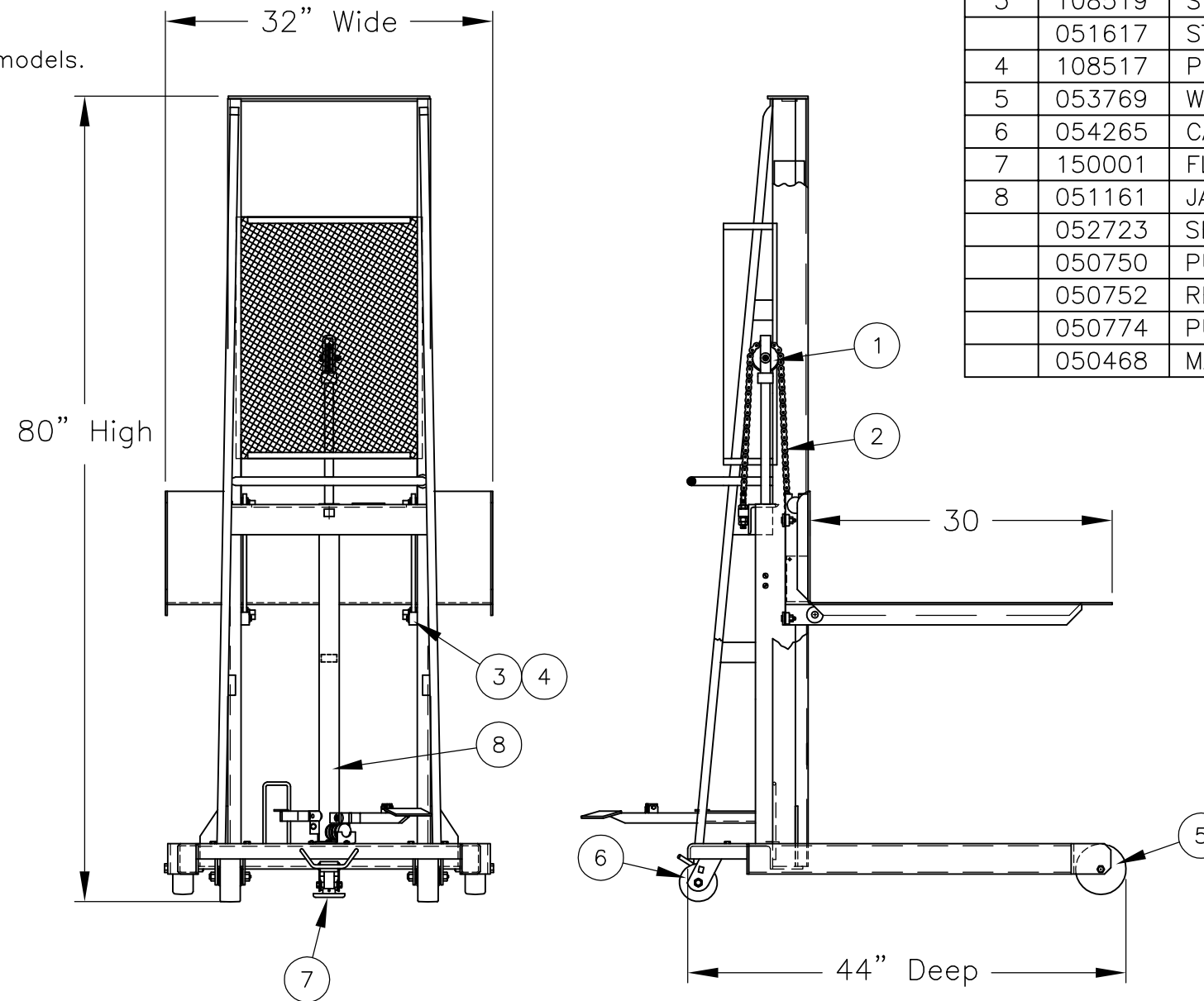

LARGE ECONOMY PLATFORM MODEL

260051 ESPL-68-3032

Platform: 30x32 w/5.25" lowered height
 Lift Height: 68"
 Load Center: 18"
 Base leg span: 25.5" Inside
 32" Outside
 Weight: 273 lbs
 Capacity: 1,000 lbs
 Boxed: No

THIS DRAWING IN ALL PARTICULARS IS WESCO INDUSTRIAL PRODUCTS INC. PROPERTY. ALL RIGHTS OF DESIGN, INVENTION OR USE OF ARE RESERVED.

PRINT ISSUED

Oct. 12, 2006

WESCO MANUFACTURING
ENGINEERING DEPARTMENT

APP	WESCO INDUSTRIAL PRODUCTS INC.		LANSDALE		PENNA. 19446	
	PART NAME			DRAWN:		
ECN & DATE	ESPL-68-3032			CHECKED:		
	TOLERANCE UNLESS OTHERWISE SPECIFIED			APP. ENGR.		
REV.	FRACTION		3 PLACE DECIMAL	2 PLACE DECIMAL		SCALE: 1" = 16"
	± 1/64		± .005	± .01		B- 260051
	ANGULAR ± 1-1/2'		SHEET 1	OF 1	REV	
BREAK ALL SHARP EDGES AND REMOVE ALL BURRS						