

260047

REPLACEMENT PARTS LIST  
56"/60" Stacker

1	260143	CHAIN ROLLER ASS'Y	1
2	050770	LIFT CHAIN ASS'Y (56/60")	1
3	108519	STABILIZER ROLLER	4
	051617	STABILIZER ROLLER KIT	
4	108517	PLATFORM ROLLER	4
5	053769	WHEEL: 5x2, PHENOLIC ASS'Y	2
6	054265	CASTER: SWIVEL 4x2 PHENOLIC	2
7	150001	FLOOR LOCK: NEW STYLE	1
8	051151	JACK ASS'Y (56/60")	1
	052723	SEAL KIT	1
	050750	PUMPING PEDAL ASS'Y (PL/SPL)	1
	050752	RELIEF PEDAL ASS'Y (PL/STCKR)	1
	050754	PUMPING RELEASE VALVE KIT	1
	050468	MAGNET SPACER ASS'Y	1

STANDARD/ECONOMY LINE FORK MODEL HYDRAULIC STACKERS

- Floor locks, safety screen and foot guard are standard on all models.
- Forks touch the floor on all fork models.
- Front phenolic wheels are 5" diameter.
- Rear Phenolic swivel casters are 4" diameter.
- Hydraulic jack manufactured by WESCO in U.S.A
- Frame and lift heights vary among models.
- "S" tandard line features one piece platform guide rail.
- "E" conomy line offers an economical price value.

ECONOMY FORK MODEL

260047                      ESFL-56-25

Fork:                      1" thick x 3" Wide x 25" long

Lift Height:              56"

Load Center:            15"

Base leg span:         15" Inside  
                              21" Outside

Capacity:                1,000 lbs

Weight:                  258 lbs

Boxed:                    No

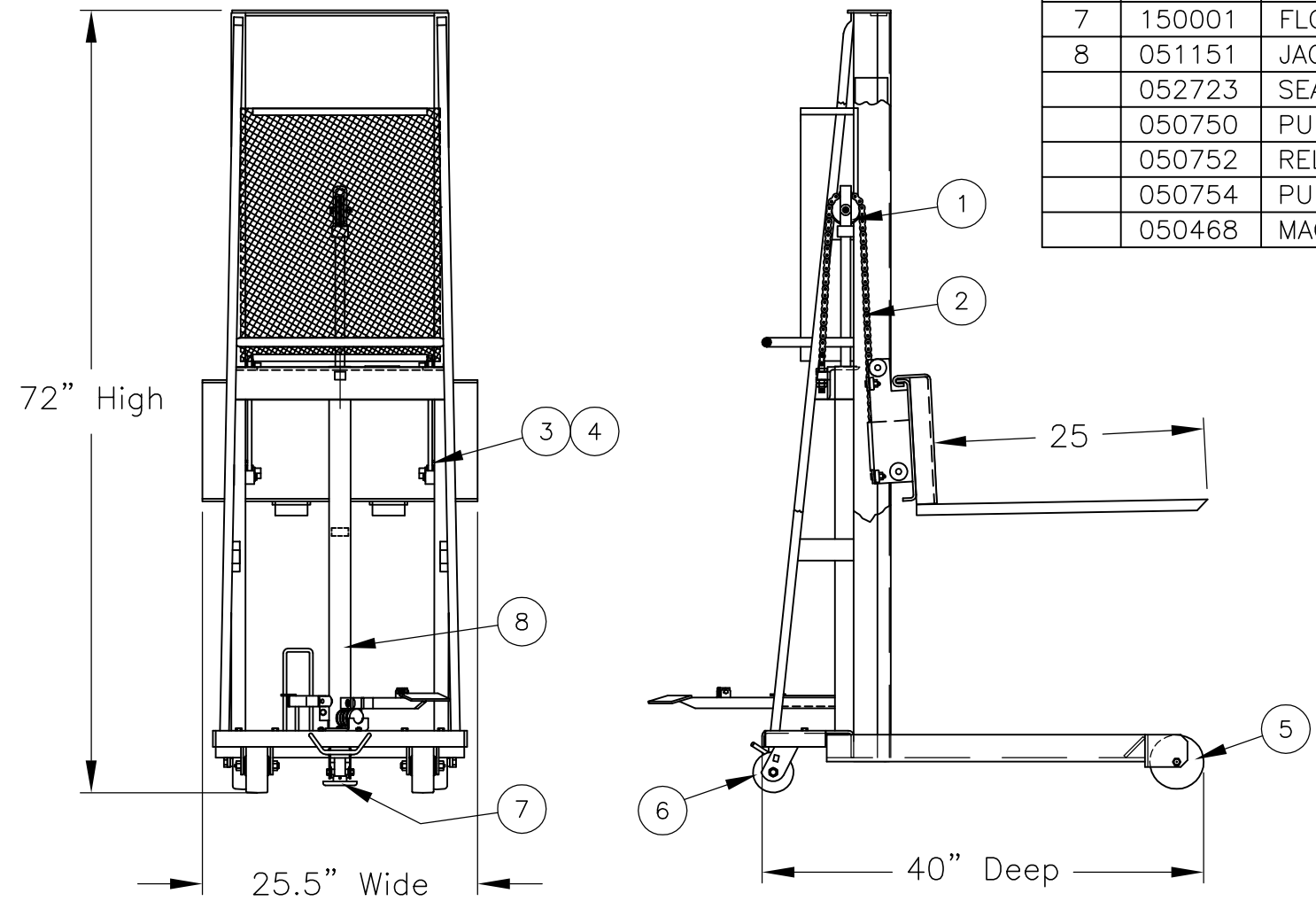

PRINT ISSUED

MAY 17, 2006

WESCO MANUFACTURING  
ENGINEERING DEPARTMENT

APP	WESCO INDUSTRIAL PRODUCTS INC.	
	LANSDALE	PENNA. 19446
ECN & DATE	PART NAME	DRAWN: WEW 10-16-98
	ESFL-56-25	CHECKED:
		APP. ENGR.
REV.	TOLERANCE UNLESS OTHERWISE SPECIFIED	
	FRACTION	3 PLACE DECIMAL      2 PLACE DECIMAL
	± 1/64	± .005                      ± .01
	ANGULAR ± 1-1/2'	SHEET 1 OF 1
BREAK ALL SHARP EDGES AND REMOVE ALL BURRS		SCALE: 1" = 16"
		B-260047      REV