

REPLACEMENT PARTS LIST

64"/68" Stacker

1	260143	CHAIN ROLLER ASS'Y	1
2	050771	LIFT CHAIN ASS'Y (64/68")	1
3	108519	STABILIZER ROLLER	4
	051617	STABILIZER ROLLER KIT	
4	108517	PLATFORM ROLLER	4
5	053769	WHEEL: 5x2, PHENOLIC ASS'Y	2
6	054265	CASTER: SWIVEL 4x2 PHENOLIC	2
7	150001	FLOOR LOCK: NEW STYLE	1
8	051161	JACK ASS'Y (64/68")	1
	052723	SEAL KIT	1
	050750	PUMPING PEDAL ASS'Y (PL/SPL)	1
	050752	RELIEF PEDAL ASS'Y (PL/STCKR)	1
	050774	PUMPING RELEASE VALVE KIT	1
	050468	MAGNET SPACER ASS'Y	1

"S" STANDARD & "E" CONOMY LINE PLATFORM HYDRAULIC STACKERS

- Floor locks, safety screen and foot guard are standard on all models.
- Forks touch the floor on all fork models.
- Front phenolic wheels are 5" diameter.
- Rear Phenolic swivel casters are 4" diameter.
- Hydraulic jack manufactured by WESCO in U.S.A
- Frame and lift heights vary among models.
- "S" tandard line features one piece platform guide rail.
- "E" conomy line offers an economical price value.

ECONOMY PLATFORM MODEL

260045 ESPL-68-2424

Platform: 24x24 w/5.75" lowered height  
 Lift Height: 68"  
 Load Center: 15"  
 Base leg span: 15" Inside  
 21" Outside  
 Weight: 234 lbs  
 Capacity: 1,000 lbs  
 Boxed: No

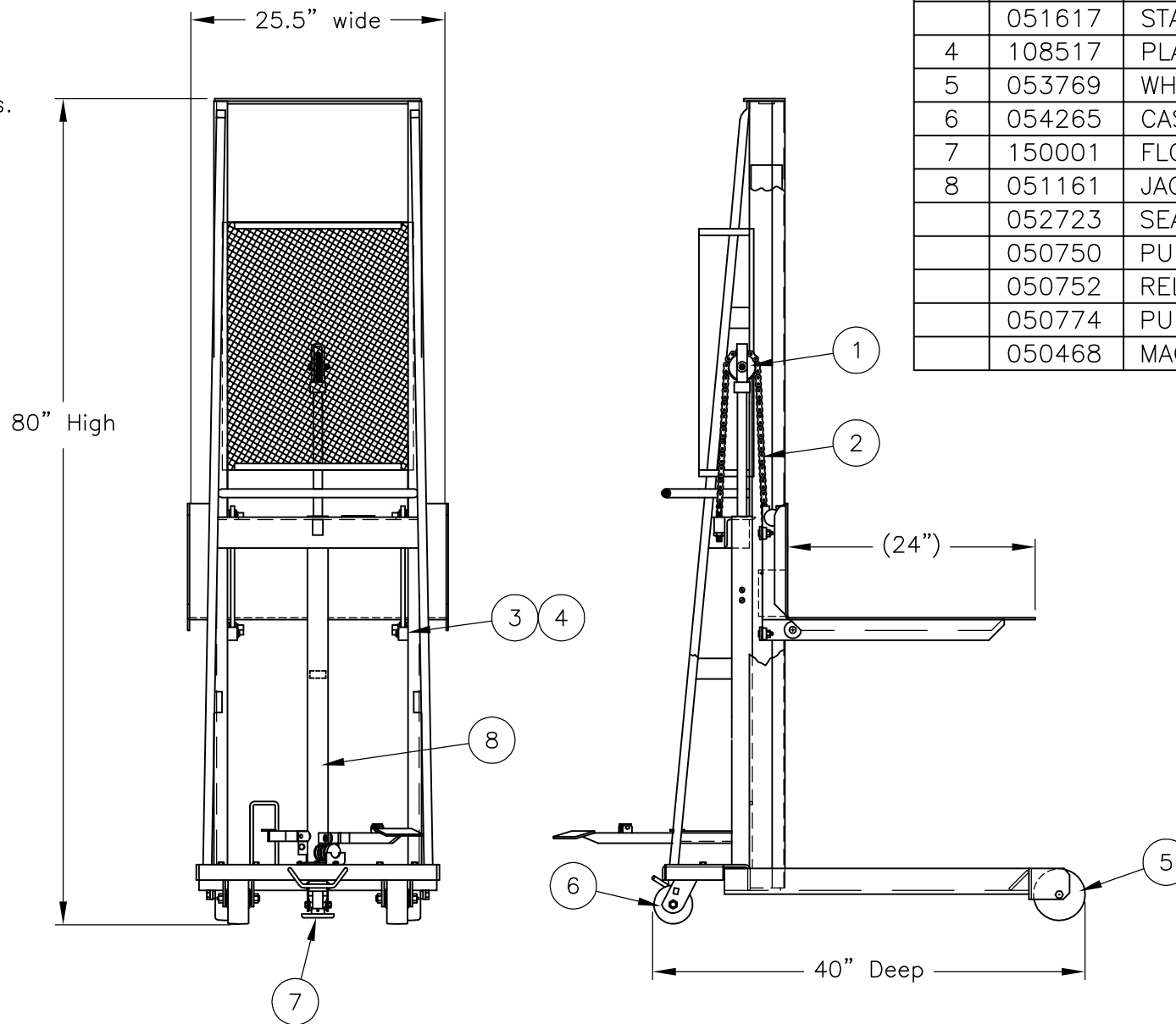

PRINT ISSUED  
 Oct. 12, 2006  
 WESCO MANUFACTURING  
 ENGINEERING DEPARTMENT

WESCO INDUSTRIAL PRODUCTS INC.  
 LANSDALE PENNA. 19446

PART NAME	ESPL-68-2424	DRAWN: WEW 10-16-98
TOLERANCE UNLESS OTHERWISE SPECIFIED		CHECKED:
FRACTION 3 PLACE DECIMAL 2 PLACE DECIMAL		APP. ENGR.
± 1/64 ± .005 ± .01		SCALE: 1" = 16"
ANGULAR ± 1-1/2' SHEET 1 OF 1		B- 260045
BREAK ALL SHARP EDGES AND REMOVE ALL BURRS		REV

APP  
 ECN & DATE  
 REVISIONS  
 REV.